

# Diaphragm Valves

## Replaceable-Seat Pneumatic Diaphragm Valves DPX Series

### Introduction

Replaceable-Seat Pneumatic Diaphragm Valves are suitable for applications requiring frequent valve maintenance and replacement, such as precursor containers and canisters. Their easy operation, long cycle life, and excellent sealing performance help to reduce costs for customers

### Features

- ⦿ Easily replaceable valve seat, without need for special tools
- ⦿ Valve seat assembly with perfectly symmetrical structure to eliminate need to distinguish the orientation of seats
- ⦿ Actuator cylinder plate color-coded for easy identification of replaceable-seat valves



### Technical Data

Port Size	1/4"	
Flow Coefficient (Cv)	0.3	
Orifice Size	0.16 in. (4.1 mm)	
Working Pressure	Vacuum to 250 psig (17.2 bar)	
Pneumatic Actuator Working Pressure	60 ~ 90 psig (4.2 ~ 6.2 bar)	
Working Temperature	PCTFE: -10 ~ 176 °F (-23 ~ 80 °C) PFA: -10 ~ 302 °F (-23 ~ 150 °C)	
Leak Rate (Helium)	Internal	$\leq 1 \times 10^{-9}$ std cm <sup>3</sup> /s
	External	$\leq 1 \times 10^{-9}$ std cm <sup>3</sup> /s

### Flow Data

Air @ 70 °F (21 °C)  
Water @ 60 °F (16 °C)

Pressure Drop to Atmosphere psig (bar)	Air (l/min)	Water (l/min)
10 (0.68)	96	3.6
50 (3.4)	250	7.9
100 (6.8)	450	11.0

### Process Specification

Process	Material	
	316L SS	316L VAR
Process Specification	Standard Cleaning and Packaging (FC-01) Special Cleaning and Packaging (FC-02)	Ultra High Purity (FC-03)
Wetted Surface Roughness	Ra 5 μin. (0.13 μm)	
Polishing Process	Electropolished	

Note: Refer to page P-01 for a detailed description of Process Specification.

## Major Materials of Construction

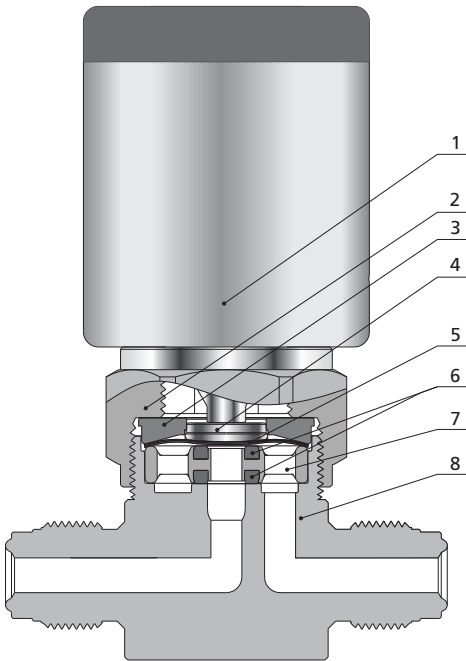

Item	Component	Material/Specification
1	Actuator	Aluminum
2	Bonnet Nut	316 SS/ASTM A479
3	Bonnet	S17400/ASTM A564
4	Button	316 SS/ASTM A479
5	Diaphragm (2)	Cobalt Alloy/AMS 5876
6	Seat	PCTFE/ASTM D1430 or PFA/ASTM D3307
7	Seat Retainer	316L SS or 316L VAR
8	Body	316L SS or 316L VAR

Normally Closed Pneumatic Model  
(Replaceable-Seat Type)

## Dimensions and Ordering Information

Dimensions, in inches (millimeters), are for reference only.

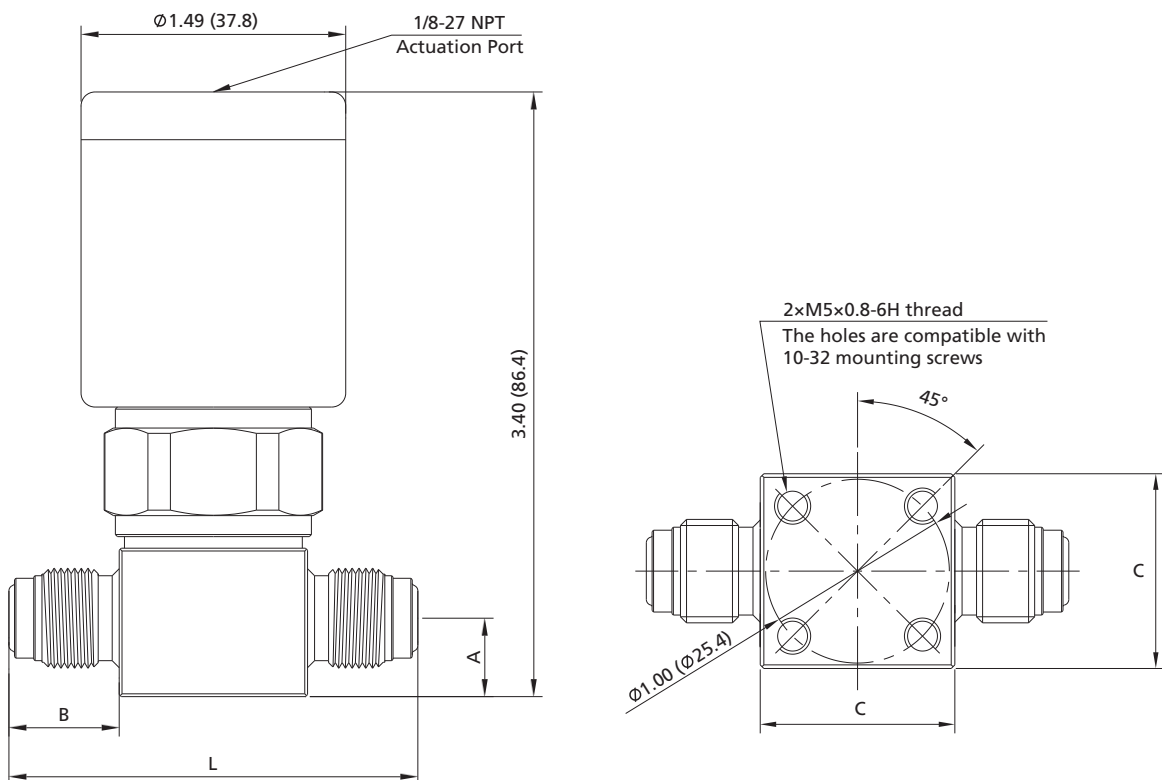

## 03 Diaphragm Valves

Basic Ordering Number	Connection Type and Size	Dimension, in. (mm)			
		A	B	C	L
DPX□□-TB4-	1/4" x 0.035" Tube Butt Weld	0.44 (11.2)	0.30 (7.6)	1.06 (26.9)	1.74 (44.2)
DPX□□-TB6-	3/8" x 0.035" Tube Butt Weld	0.44 (11.2)	0.26 (6.6)	1.06 (26.9)	1.74 (44.2)
DPX□□-FFR4-	1/4" Rotatable Female FR Metal Gasket Face Seal Fitting	0.44 (11.2)	0.86 (21.8)	1.06 (26.9)	2.78 (70.6)
DPX□□-RFR4-	1/4" Rotatable Male FR Metal Gasket Face Seal Fitting	0.44 (11.2)	0.86 (21.8)	1.06 (26.9)	2.78 (70.6)
DPX□□-FR4-	1/4" Integral Male FR Metal Gasket Face Seal Fitting	0.44 (11.2)	0.62 (15.7)	1.06 (26.9)	2.30 (58.4)

## Service Kit Ordering Information

Basic Ordering Information	Description	Remarks
□□DQX-KIT	Includes 1 piece of seat assembly (seat material: PCTFE), 2 pieces of cobalt alloy diaphragms, and maintenance instructions	Applies to replaceable-seat diaphragm valves
□□DQX-A-KIT	Includes 1 piece of seat assembly (seat material: PFA), 2 pieces of cobalt alloy diaphragms, and maintenance instructions	



## Ordering Number Description

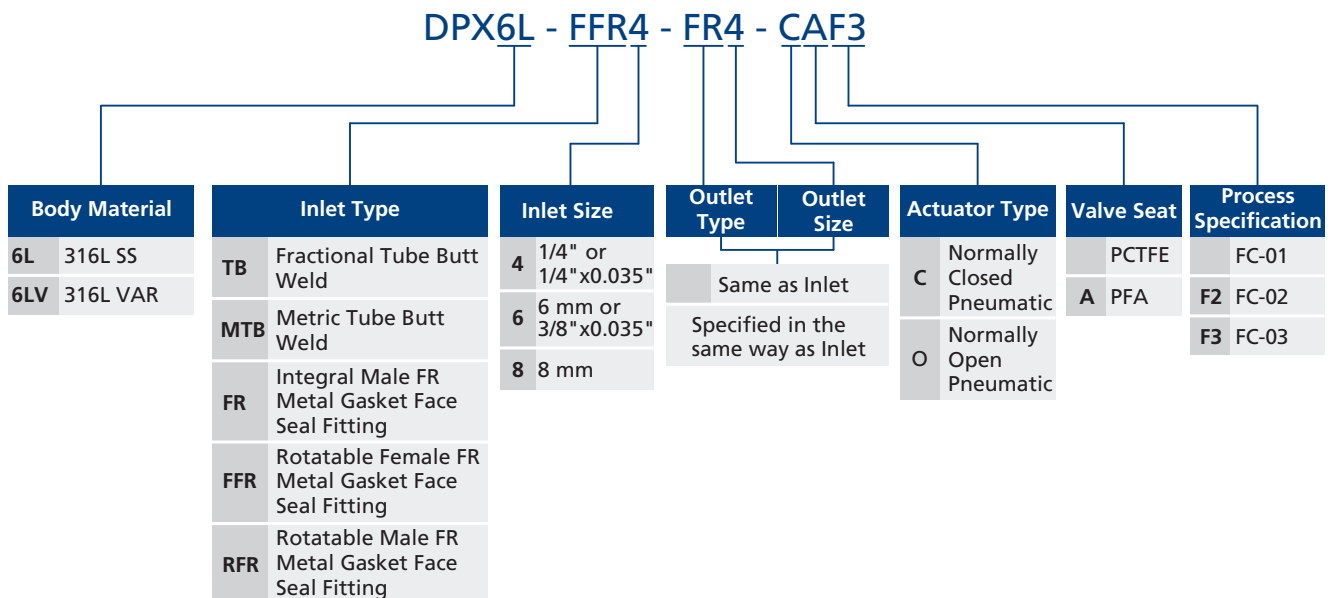

Note: "Ordering Number Description" is a reference to understand the combination rules of FITOK product part number. Not all combinations are available. Should you have any questions, please contact FITOK Group or our authorized distributors.